



Press Brake Tooling
Product Range

Making the Impossible, Possible

Welcome to **Rolla-V**

► **We are Rolla-V, world-leading designers and manufacturers of specialist Press Brake Tools.**

Our state-of-the-art facilities reflect the tradition of generations of engineering in the industrial heart of the United Kingdom.

Based in the West Midlands, at the hub of the motorway network, it's easy to visit for a demonstration or to view your tools in action prior to delivery. With over 80 years of experience, Rolla-V supplies the most comprehensive range of Press Brake Tools available today.



With continued investment and an unrivalled reputation for quality and service, Rolla-V is the global centre of excellence for Press Brake Tools and bending technology.

We designed and patented the revolutionary Rolla-V over fifteen years ago. Since then, Rolla-V has become a favourite of every Press Brake manufacturer in the world, and won Innovative Product of the Year. Rolla-V is now sold by all major press brake tooling companies.



Rolla-V provides the definitive answer if you need to:

- Bend stainless steel, aluminium (or any aesthetic materials) with little or no marking
- Bend small flanges
- Bend near to a hole or slot without distortion
- Avoid tool contamination
- Prevent secondary expensive and unnecessary rework.





▶ **As the home of the revolutionary patented Rolla-V.**

We supply Press Brake Tools, from stock, for every make of Press Brake in the world including **Adira, Amada, Baykal, Bystronic, Durma, LVD, Safan and Trumpf.**

Most of our products are available for immediate dispatch, enabling you to tackle any project, of any size with complete confidence.

We have full CNC Press Brake testing facilities and also supply guillotine blades and a comprehensive range of auxiliary equipment.

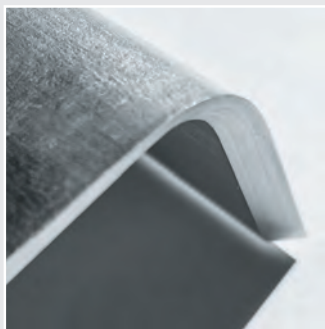
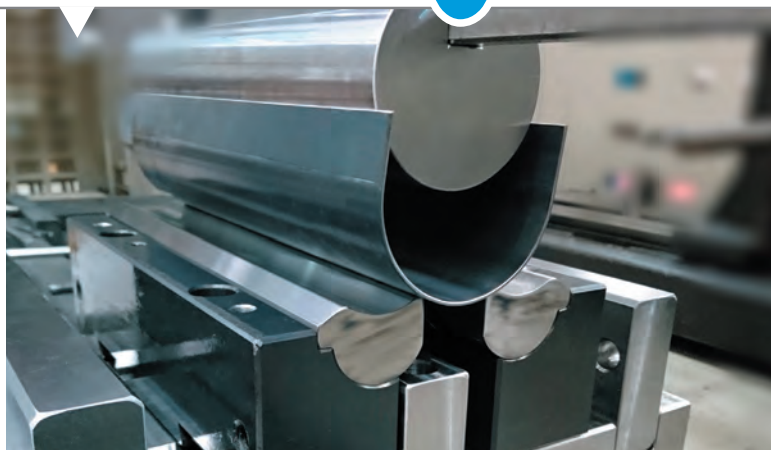

Technical Spec.

The Rolla-V Range of Tools

▶ **Rolla-V dies are available to suit any manufacturer's machine.**

Several fixed sizes are offered as well as adjustable models which are ideal for heavy plate or large radius work.

Appropriate insert materials are used to suit the typical applications for each size of Rolla-V tool, although custom materials may be available on request.

Custom sizes and widths are also available for specific applications. Please call us to find out more.

Non-Standard lengths are available to order on all models

Application

RVP (models 1, 2 and 3) are; 60mm clamping widths

Suitable for Amada, Atlantic, Adira, Bystronic Euro, Beyeler Euro-B, CR Electronic, Durmazlar, Ermaskan, Gasparini, Guifil, Haco, Promecam.

RVS (models 1, 2) are 14mm tang

Suitable for Amada style single V holder.

RVT (models 1, 2 and 3) are 12.7mm/13.0mm tang

Suitable for Bystronic, Hammerle, Beyeler, Edwards, Safan, SMD, Trumpf.

RVT90 (models 1, 2 and 3) are 12.7mm offset tang

Suitable for LVD with offset tang.

RVM (models 2.5, 3, 3.5 and 4)

Universal clamping with base or tang – all styles are available – suitable for any machine brand.

If you cannot see your machine type listed here we can provide advice and make custom fittings to your specification – please call us.

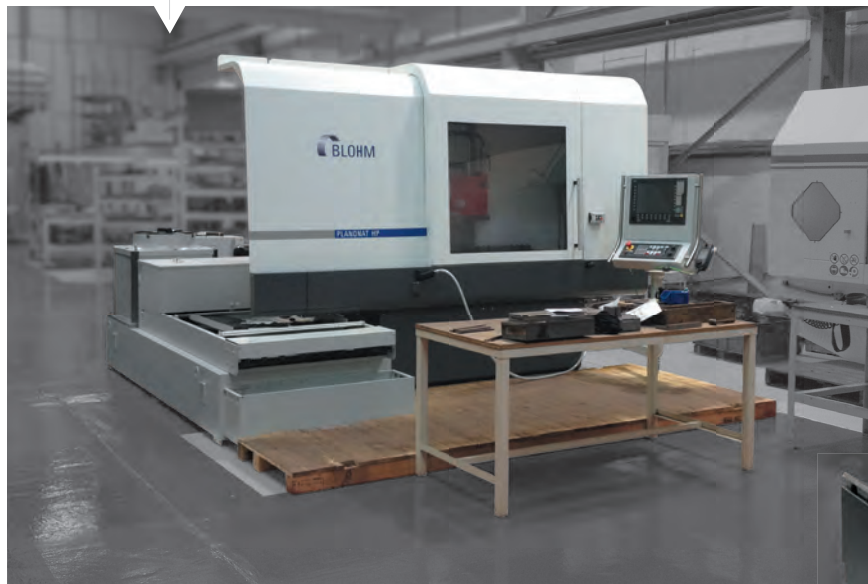

Rolla-V Materials

Inserts	All models	Through hardened up to HRC60. 70 Rockwell available on request.
Body	All models	42CrMo4 tensile strength 1100-1200M/mm ² surface hardened to HRC55

Non-standard insert materials and HRC values are available for specific applications – please call us

Advantages of using Rolla-V

- ▶ Highly precision ground
- ▶ Modular
- ▶ Avoid traditional bending marks
- ▶ Minimal marking
- ▶ Extremely short flanges possible
- ▶ No tool material cross contamination
- ▶ Bend close to holes and cut-outs with no deformation
- ▶ Fewer tool changes
- ▶ Bends laser cut sheets with no tool damage
- ▶ Ideal for radius bending
- ▶ Exact inside radius
- ▶ Ideal for tapered or feathered edges
- ▶ Bends up to 30mm thick material (subject to model selected)

Application and Technical Data

	max. load capacity (t/m)	material thickness (mm)	min. bending angle	A tonnage required (t)	B min. outside flange (mm)	C max. outside radius
XT1 non-adjustable style Max recommended thickness 1.2 mm	50	0.3	60°	5.0	3.2	2.2
	50	0.8	60°	13.0	3.2	2.2
	50	1.2	60°	30.0	3.2	2.2
XT2 non-adjustable style Max recommended thickness 2.3 mm	70	0.5	60°	5.0	6.1	4.1
	70	1.0	60°	10.0	6.1	4.1
	70	2.0	60°	33.0	6.1	4.1
Model 1 non-adjustable style Max recommended thickness 1.5 mm (2.0 mm thickness may be possible)	100	0.7	40°	5.0	4.2	3.0
	100	1.1	35°	13.0	4.2	2.6
	100	1.5	35°	27.0	4.2	2.2
Model 2 non-adjustable style Max recommended thickness 3.0 mm (4.0 mm thickness may be possible)	150	2.0	59°	21.0	9.3	6.0
	150	3.0	47°	55.0	9.3	5.0
	150	3.2	47°	65.0	9.3	4.8
Model 2.5 non-adjustable style Max recommended thickness 6.3 mm	250	2.0	46°	10.0	18.6	13.2
	250	4.0	46°	47.0	18.6	12.0
	250	6.0	55°	127.0	18.6	9.8
Model 3 non-adjustable style Max recommended thickness 6.0 mm (4.0 mm thickness may be possible)	250	2.0	68°	7.0	22.5	13.9
	250	4.0	47°	34.0	22.5	11.9
	250	6.0	50°	90.0	22.5	9.9
Model 3.5 non-adjustable style Max recommended thickness 10.0 mm (12.0 mm thickness may be possible)	250	6.0	75°	44.0	39.0	20.0
	250	8.0	75°	85.0	39.0	20.0
	250	10.0	75°	145.0	39.0	20.0
Model 4 non-adjustable style Max recommended thickness 16.0 mm	300	6.0	78°	26.0	56.6	36.4
	300	8.0	76°	50.0	56.6	36.4
	300	12.0	73°	129.0	56.6	36.4

Adjustable models	Min / Max	Max Load
RVHD2	16mm - 30mm	200
RVHD2.5	28mm - 69mm	250
RVHD3	38mm - 110mm	350
RVHD4	69mm - 220mm	350

Adjustables are usually used for bending thick materials or for bending large radii - because specific material specs vary we do not provide detailed bend data. Flaring or hole distortion is much reduced, but is influenced by material specification. Radius work is greatly affected by spring-back of the specific material being bent. Minimum flange sizes are greatly affected by the squareness of the component edge.

XT1

For thinner gauge material

- ▶ **Thickness**
0.3mm -1.2mm
- ▶ **Standard Lengths**
50mm, 100mm, 200mm and 500mm
- ▶ **Minimum Flange**
3.2mm
- ▶ **Maximum capacity**
50 Tonnes

The latest addition to the Rolla-V family - the XT1 and XT2 are specifically made for thinner gauge material.

These tools are ideal for thin materials with short flanges or intricate components.

	max. load capacity (t/m)	material thickness (mm)	min. bending angle	tonnage required (t)	min. outside flange (mm)	max.outside radius
Model XT1 fixed style	50	0.3	60°	5.0	3.2	2.2
	50	0.8	60°	13.0	3.2	2.2
	50	1.2	60°	30.0	3.2	2.2

Max.recommended thickness = 1.2mm
Equivalent V size 4.5mm

XT1

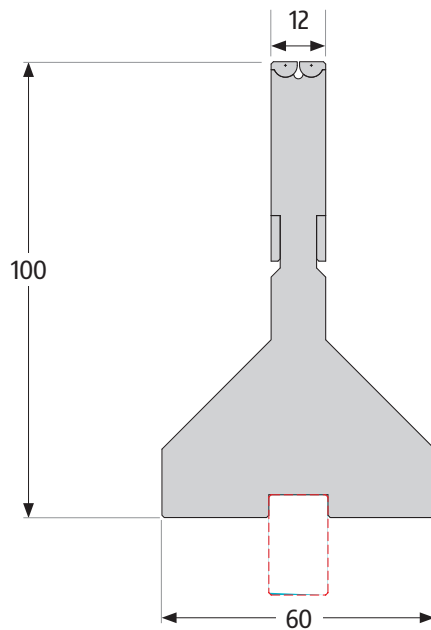

500mm	5.5 kg
100mm	1.0 kg

XT2

For thinner gauge material

- ▶ **Thickness**
0.5mm - 2.3mm
- ▶ **Standard Lengths**
50mm, 100mm, 200mm and 500mm
- ▶ **Minimum Flange**
6.1mm
- ▶ **Maximum capacity**
70 Tonnes



	max. load capacity (t/m)	material thickness (mm)	min. bending angle	tonnage required (t)	min. outside flange (mm)	max.outside radius
Model XT2 fixed style	70	0.5	60°	5.0	6.1	4.1
	70	1.0	60°	10.0	6.1	4.1
	70	2.0	60°	33.0	6.1	4.1

Max.recommended thickness = 2.3mm
Equivalent V size 8.6mm

XT2

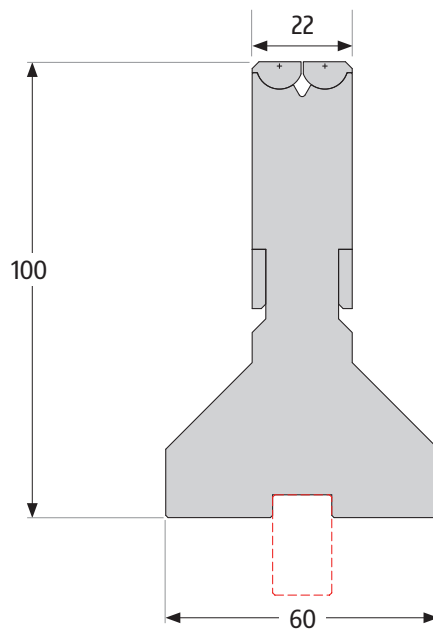

500mm	8.0 kg
100mm	1.6 kg

Model 1

- ▶ Castellated inserts to give more contact area
- ▶ **Standard Lengths**
500mm, 100mm and 440mm segmented
- ▶ **Segmented**
440mm lengths include:
200mm, 100mm, 50mm, 30mm,
25mm, 20mm, 15mm

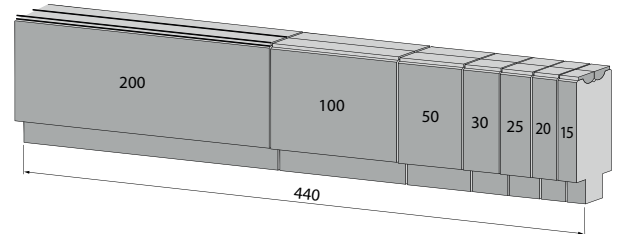

	max. load capacity (t/m)	material thickness (mm)	min. bending angle	tonnage required (t)	min. outside flange (mm)	max. outside radius
Model 1 fixed style	100	0.7	40°	5.0	4.2	3.0
	100	1.1	35°	13.0	4.2	2.6
	100	1.5	35°	27.0	4.2	2.2

Max. recommended thickness = 1.5mm (2.0mm thickness may be possible)
Equivalent V size 7mm

RVP60-1

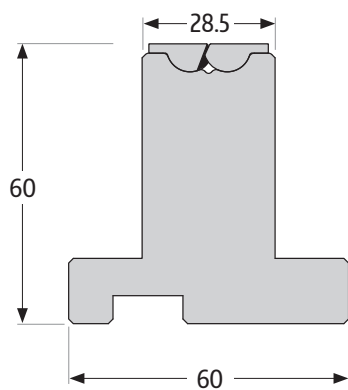

500mm	6.9 kg
440mm segmented	6.1 kg
100mm	1.4 kg

RVS80-1

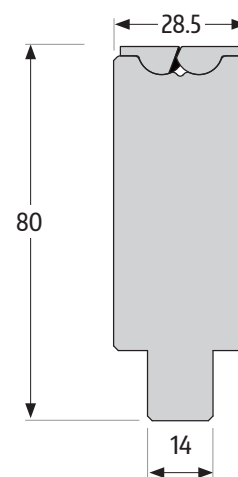

500mm	6.3 kg
440mm segmented	5.8 kg
100mm	1.3 kg

Model 1



RVT55-1

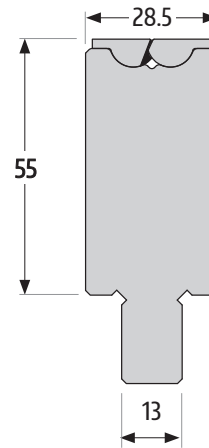

500mm	5.5 kg
440mm segmented	5.0 kg
100mm	1.1 kg

RVT90-1

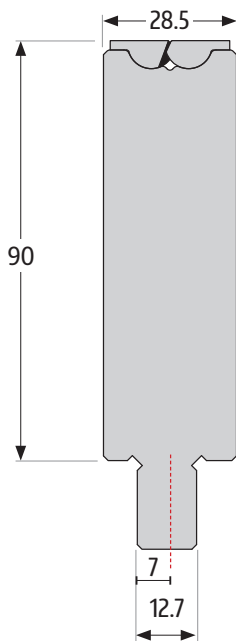

500mm	8.5 kg
440mm segmented	7.8 kg
100mm	1.7 kg

RVT100-1

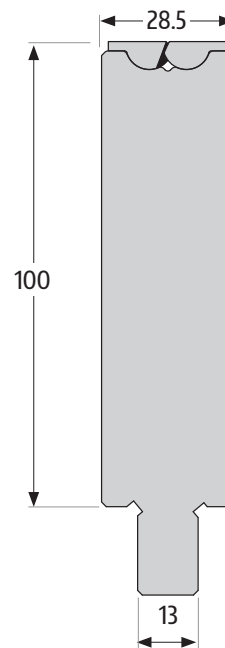

500mm	9.4 kg
440mm segmented	8.6 kg
100mm	1.8 kg

Model 2

Standard lengths

500mm, 100mm and 450mm segmented

Segmented

450mm lengths include:

200mm, 100mm, 40mm, 35mm, 30mm, 25mm, 20mm

Segmented

'Upgrade Kit' available –

segments at 25mm, 45mm and 50mm

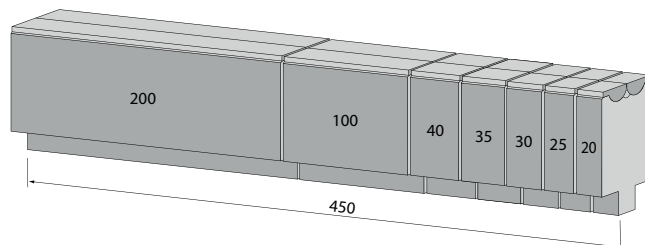

	max. load capacity (t/m)	material thickness (mm)	min. bending angle	tonnage required (t)	min. outside flange (mm)	max. outside radius
Model 2 fixed style	150	2.0	59°	21.0	9.3	6.0
	150	3.0	47°	55.0	9.3	5.0
	150	3.2	47°	65.0	9.3	4.8

Max. recommended thickness = 3.0mm (4.0mm thickness may be possible)

Equivalent V size 13mm

RVP65-2

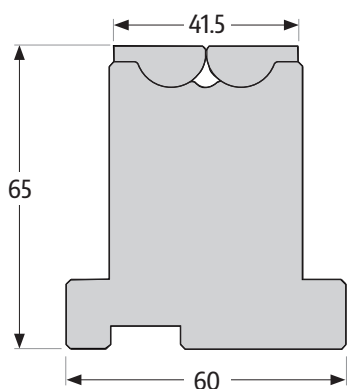

500mm	7.9 kg
450mm segmented	7.4 kg
100mm	1.6 kg

RVS80-2

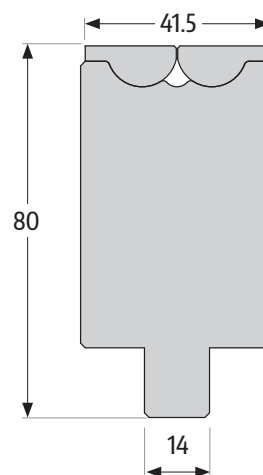

500mm	8.3 kg
450mm segmented	7.8 kg
100mm	1.7 kg

Model 2



RVT60-2

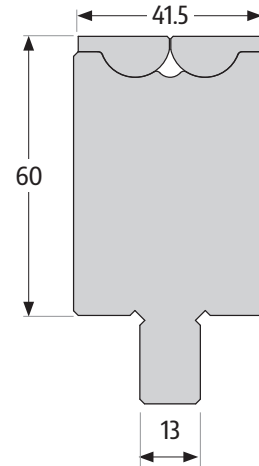

500mm	7.9 kg
450mm segmented	7.4 g
100mm	1.6 kg

RVT90-2

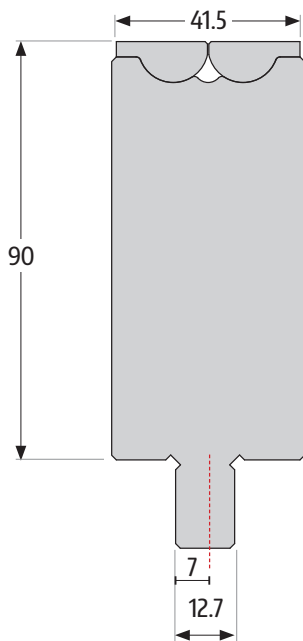

500mm	11.3 kg
450mm segmented	10.6 kg
100mm	2.2 kg

RVT100-2

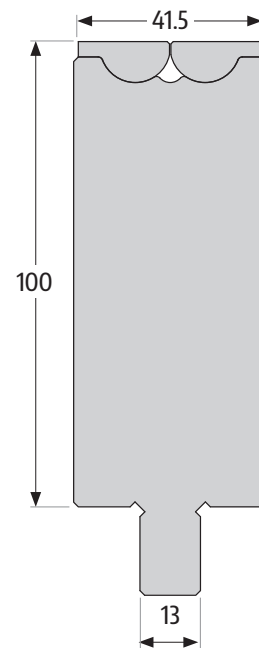

500mm	12.4 kg
450mm segmented	11.7 kg
100mm	2.5 kg

Model 2.5

▶ **Standard lengths**

500mm, 100mm and 470mm segmented

▶ **Segmented**

470mm lengths include:
200mm, 100mm, 50mm, 45mm,
40mm, 35mm

▶ **Segmented**

'Upgrade Kit' available –
segments at 25mm, 30mm and 45mm

▶ Optional inserts can be hardened up to 70 HRC on request

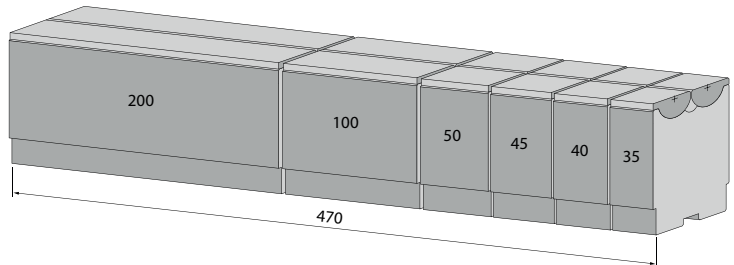

	max. load capacity (t/m)	material thickness (mm)	min. bending angle	tonnage required (t)	min. outside flange (mm)	max. outside radius
Model 2.5 fixed style	250	2.0	46°	10.0	18.6	13.2
	250	4.0	46°	47.0	18.6	12.0
	250	6.0	55°	127.0	18.6	9.8

Max. recommended thickness = 6.3mm
Equivalent V size 25mm

RVM-2.5

Available with any Tang Fitting

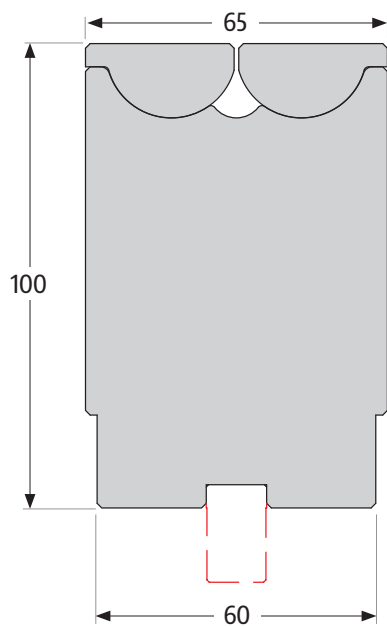

500mm	22.0 kg
470mm segmented	21.0 kg
100mm	4.4 kg



On-site

Demonstrations available



We are proud to demonstrate our products, so please let us know if you would like to see them in action



We are happy to visit you at your earliest convenience to demonstrate our comprehensive tooling range in person.

You will be able to test our tools on site and find out exactly how our range can work for you.

To arrange a personalised on-site demonstration for your business, please call us on:

+44 (0)845 500 1900



Model 3

- ▶ **Standard lengths**
500mm, 100mm and 455mm segmented
- ▶ **Segmented**
455mm lengths include:
200mm, 100mm, 60mm, 50mm, 45mm
- ▶ **Tang Sizes - RVM70-3**
60mm, 13mm, 12.7mm, 12.7mm offset
- ▶ Optional inserts can be hardened up to 70 HRC on request

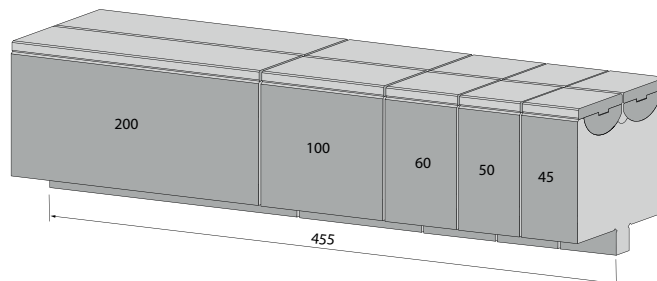

	max. load capacity (t/m)	material thickness (mm)	min. bending angle	tonnage required (t)	min. outside flange (mm)	max. outside radius
Model 3 fixed style	250	2.0	68°	7.0	22.5	13.9
	250	4.0	47°	34.0	22.5	11.9
	250	6.0	50°	90.0	22.5	9.9

Max. recommended thickness = 6.0mm (8.0mm thickness may be possible)
Equivalent V size 30mm

RVP100-3

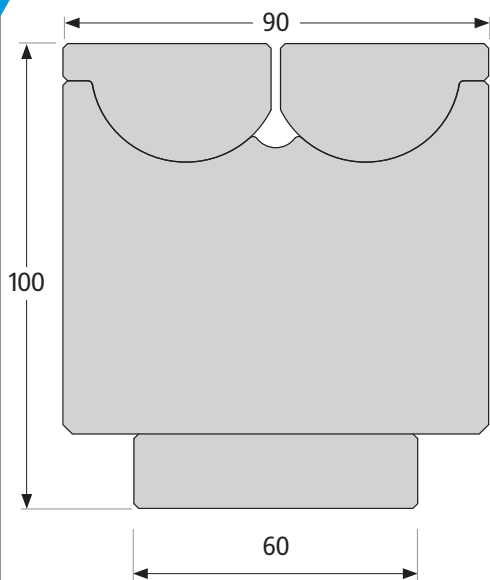

500mm	28.8 kg
455mm segmented	26.2 kg
100mm	5.8 kg

RVT100-3

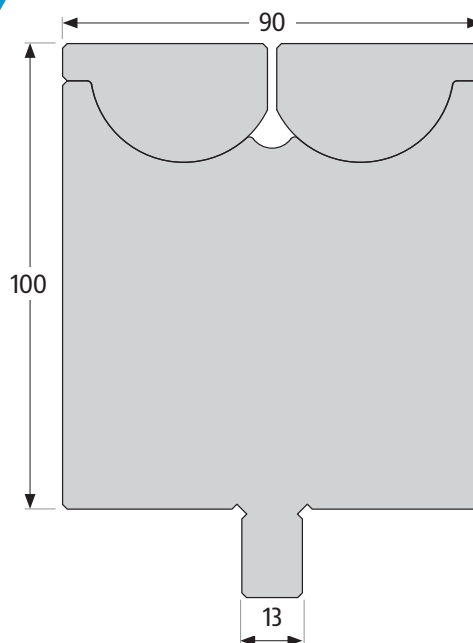

500mm	30.9 kg
455mm segmented	28.5 kg
100mm	6.2 kg

Model 3

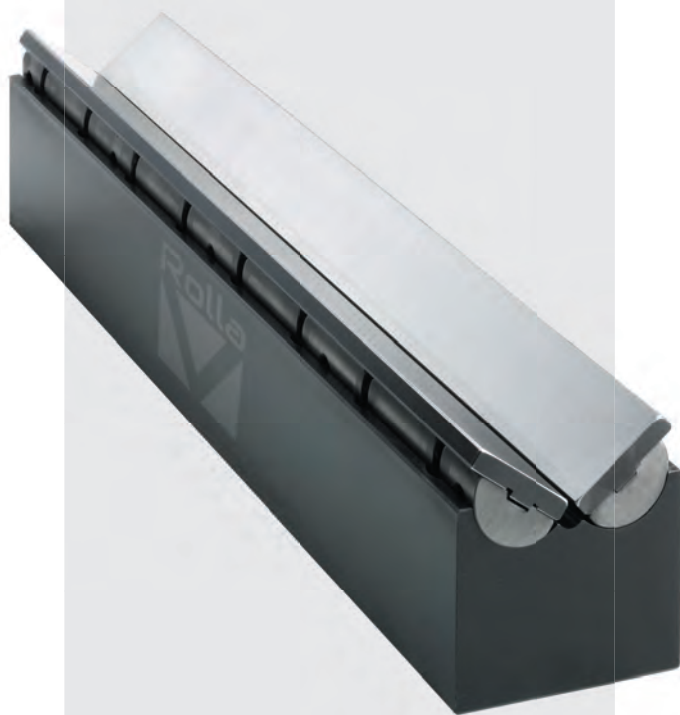

RVM70-3

Available with any base or tang fitting

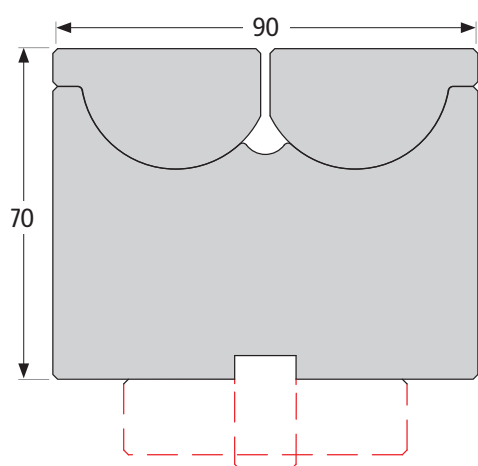

500mm	20.6 kg
455mm segmented	18.7 kg
100mm	4.2 kg



Model 3.5

- ▶ **Tang Fittings**
Available to suit all manufacturers' machines
- ▶ **Standard Lengths**
500mm and 250mm
- ▶ **Tang Sizes**
60mm, 13mm, 12.7mm, 12.7mm offset
- ▶ Optional inserts can be hardened up to 70 HRC on request



	max. load capacity (t/m)	material thickness (mm)	min. bending angle	tonnage required (t)	min. outside flange (mm)	max.outside radius
Model 3.5 fixed style	250	6.0	75°	44.0	39.0	20.0
	250	8.0	75°	85.0	39.0	20.0
	250	10.0	75°	145.0	39.0	20.0

Max.recommended thickness = 10.0mm (12.0mm thickness may be possible)
Equivalent V size 55mm

RVM-3.5

Available with any base or tang fitting

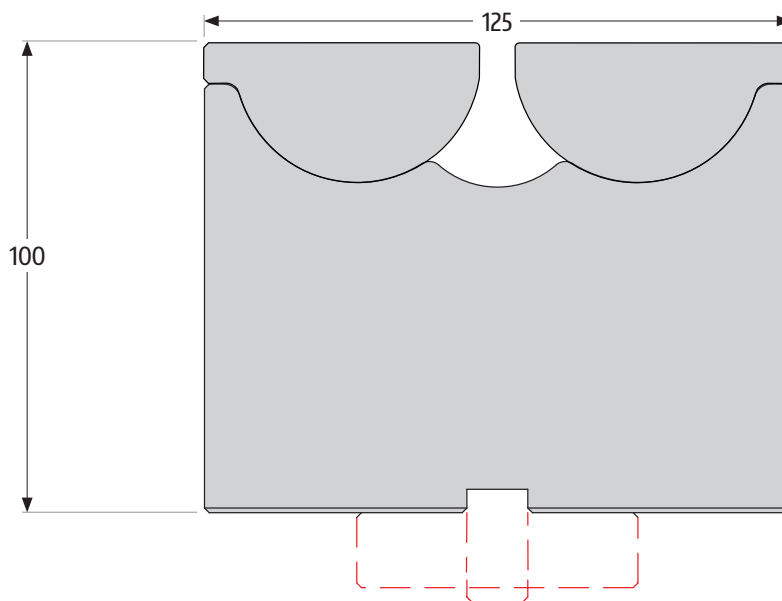

500mm 46.7 kg

250mm 23.4 kg

Please remember to order your required Tang.

Model 4



- ▶ **Tang Fittings**
Available to suit all manufacturers' machines
- ▶ **Standard Lengths**
500mm and 250mm
- ▶ **Tang Sizes**
60mm, 13mm, 12.7mm, 12.7mm offset
- ▶ Optional inserts can be hardened up to 70 HRC on request



	max. load capacity (t/m)	material thickness (mm)	min. bending angle	tonnage required (t)	min. outside flange (mm)	max. outside radius
Model 4 fixed style	300	6.0	78°	26.0	56.6	36.4
	300	8.0	76°	50.0	56.6	36.4
	300	12.0	73°	129.0	56.6	36.4

Max. recommended thickness = 16.0mm
Equivalent V size 76mm

RVM90-4

Available with any base or tang fitting

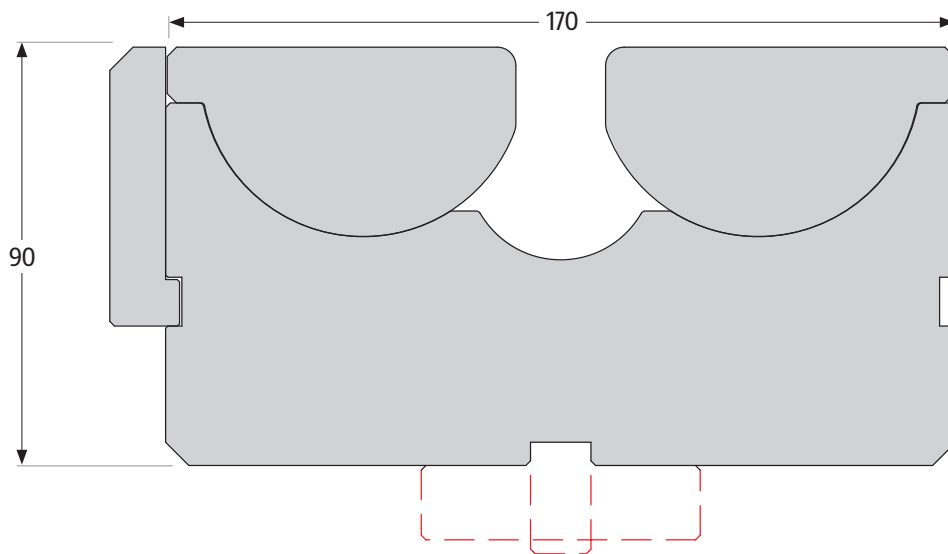

500mm	56.6 kg
250mm	28.3 kg

Please remember to order your required Tang.

Applications

Special Rolla-V range

Hemming & Joggle (Z) Tools

- ▶ Achieve a small flange and minimise safety edge marking using the Rolla-V Hemming Tool
- ▶ Minimise Joggle Form marking
- ▶ Large range of Z folds available from one tool
- ▶ Contact us if you have special applications

These products are made to order to your specification.

Please call to discuss your individual requirements.

+44 (0)845 500 1900



Hemming Tool

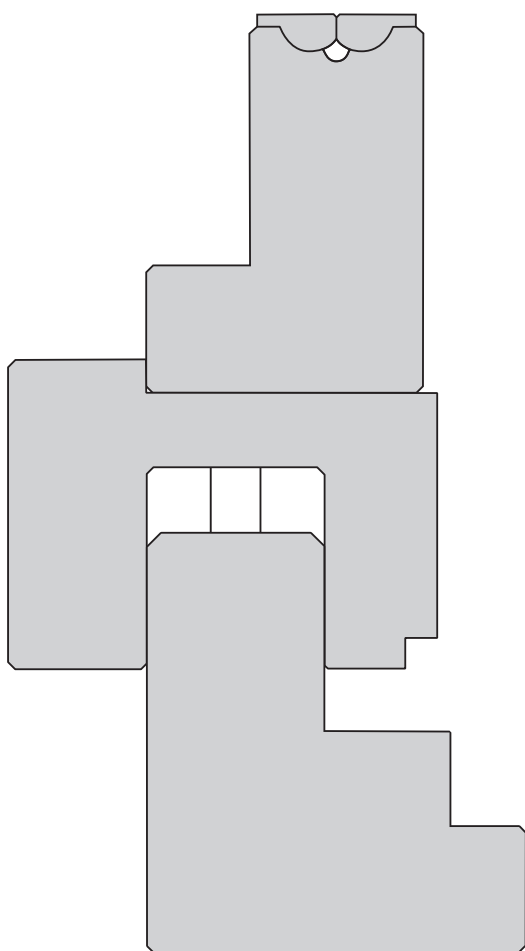

Adjustable Joggle

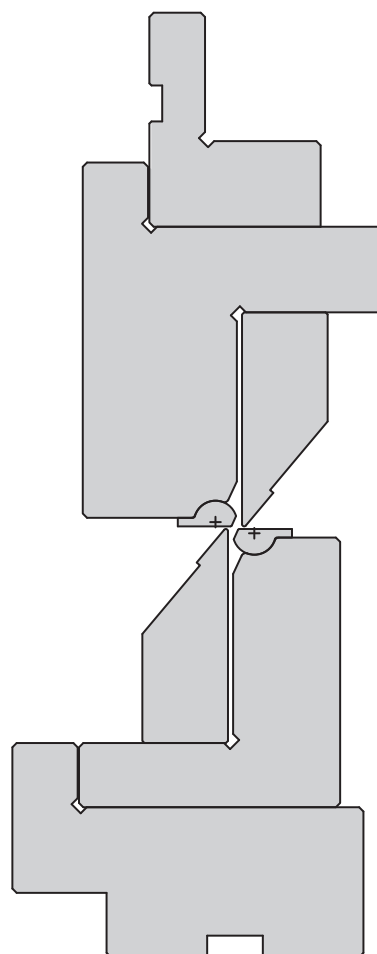

Squaring Arm

Magnetic



- ▶ Easy and fast positioning anywhere on the bottom dies
- ▶ Precise and flexible adjustability
- ▶ Adjustable angle stop/adjustment
- ▶ Mountable on all dies
- ▶ Ideal for long and thin sheet metals
- ▶ No obtrusive clamps
- ▶ Powerful magnets
- ▶ Laser marked angles
- ▶ Health and safety compliant



Magnetic Convenience



+44 (0)845 500 1900



Adjustable

Rolla-V Range

Non-standard lengths available to order

- ▶ Several fixed sizes are offered as well as adjustable models which are ideal for heavy plate or large radius work.
- ▶ Standard lengths 500mm and 250mm
- ▶ These tools are usually used for bending thicker materials or making large radius components
- ▶ Specific material specifications vary greatly so it is not feasible to provide detailed data
 - eg. minimum flange sizes are greatly affected by squareness of component edge
 - eg. flaring or hole distortion is much reduced with these tools, but is influenced by specific material type
 - eg. radius work is greatly affected by springback of specific material and flange sizes

▶ **Please call us to discuss specific applications**

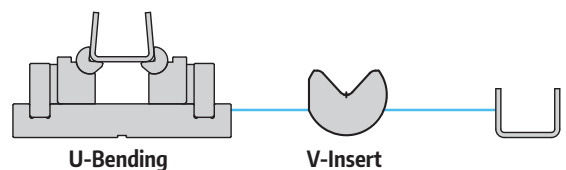
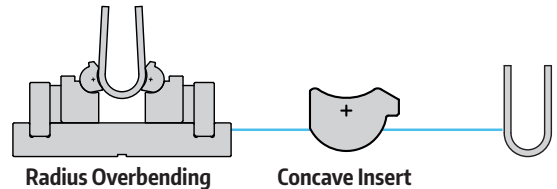
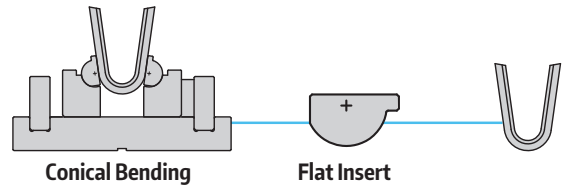
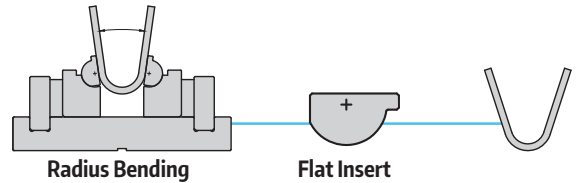
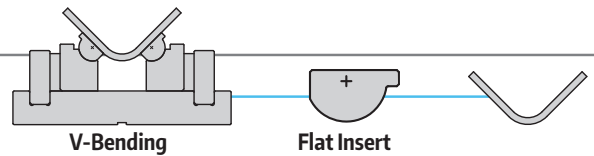

RVHD2

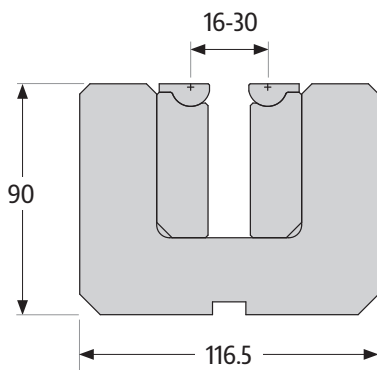

500mm	33.6 kg
250mm	16.8 kg
Maximum recommended thickness 5mm	

RVHD2.5

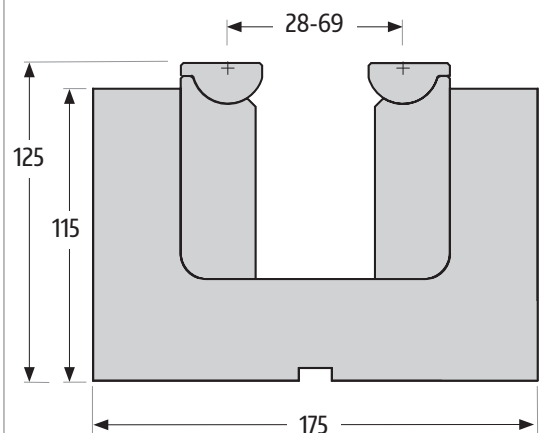

500mm	67.5 kg
250mm	33.8 kg
Maximum recommended thickness 10mm	

Adjustable

Rolla-V Range



RVHD3

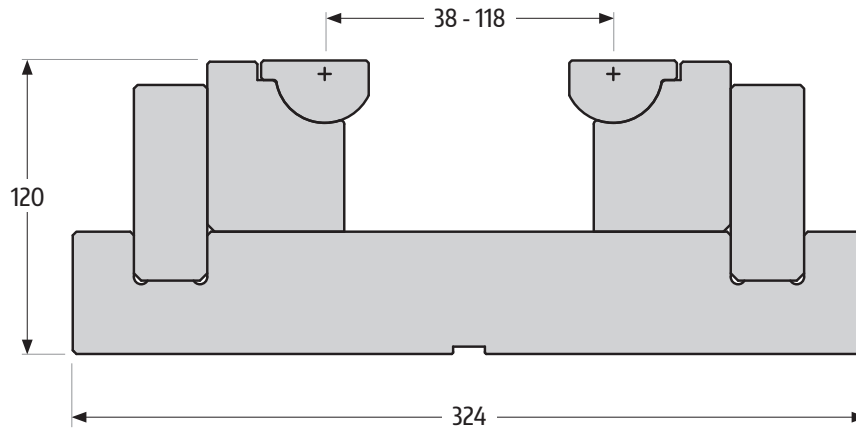

500mm	98.0 kg
250mm	49.0 kg
Maximum recommended thickness 20mm	

RVHD4

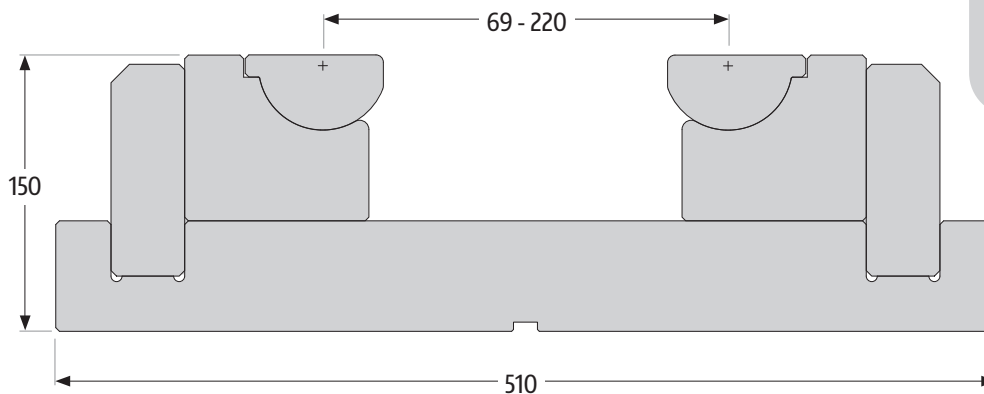

500mm	200.0 kg
250mm	100.0 kg
Maximum recommended thickness 30mm	

CNC Modular Rolla-V

The world's first Modular Rolla-V CNC Controlled Press Brake Tooling Die, change the "V" size from 55mm wide up to 142mm with a touch of one button.

Bend up to 20mm material.

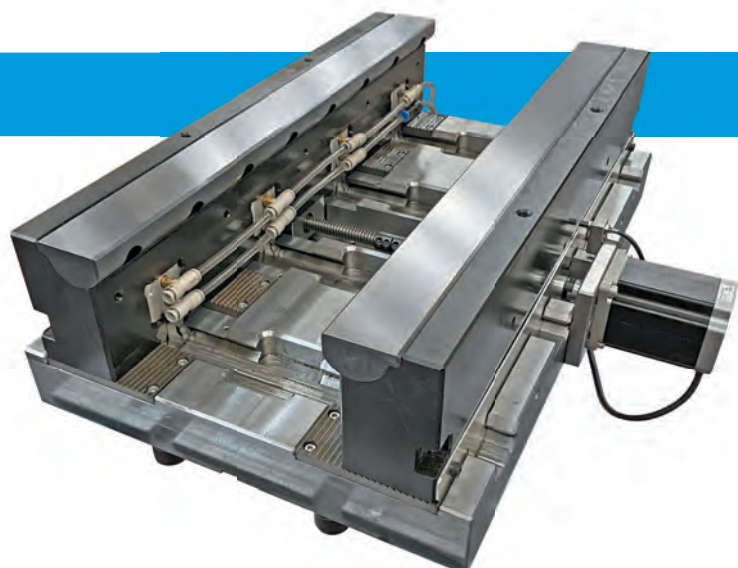

Calculations

- ▶ These formulae are for guideline purposes only – they will provide a good indicator of what tonnage, flange size or maximum outside radius is possible for a specific bend.

Our experience shows that whilst these calculations provide theoretical values, in practice it is usually possible to obtain a more favourable result.

We would recommend that if your requirement is close to the calculated value, a test bend using your material and tooling may be advisable to confirm what result is actually possible.

Key:

Dimension A  Rotor centre distance

Dimension B  Equivalent V-width for calculating flange sizes

Dimension C  Equivalent V-width for calculating tonnages (rotor at 90°)

Dimension Z  Equivalent corner radius

Dimensions

	A (mm)	B (mm)	C (mm)	Z (mm)
XT1	5.7	5.04	4.57	0.80
XT2	10.0	9.21	8.66	0.95
Model 1	8.0	7.17	6.59	1.00
Model 2	15.0	13.92	13.16	1.30
Model 2.5	28.0	26.34	25.17	2.00
Model 3	38.0	33.44	30.22	5.50
Model 3.5	60.0	57.10	55.05	3.50
Model 4	85.0	80.03	76.51	6.00

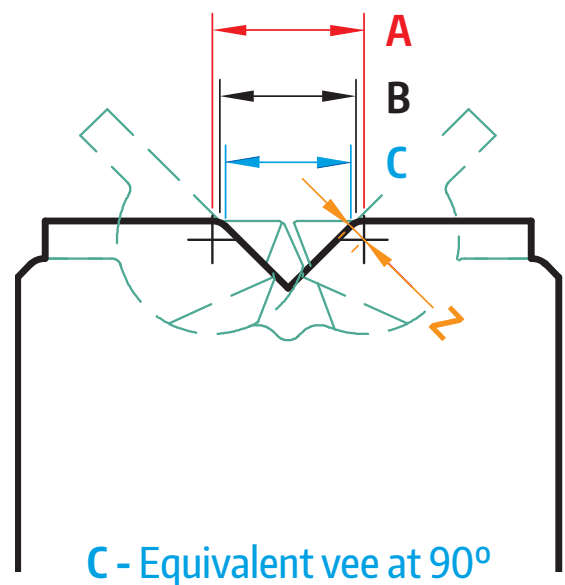

C - Equivalent vee at 90°



Force (tonnage) calculation

$$\text{Force (Kn/m)} = \frac{Rm \times T^2}{C} \times \left(1 + \frac{4 \times T}{C}\right)$$

Aluminium: Rm = 200-300 N/mm²

Mild Steel: Rm = 370-450 N/mm²

Stainless: Rm = 650-700 N/mm²

Example:

Bend force calculation example:

2mm Aluminium in a Model 2

$$\text{Force (Kn/m)} = \frac{300 \times 2^2}{13.16} \times \left(1 + \frac{4 \times 2}{13.16}\right)$$

$$91.185 \times 1.6079 = 146.62 \text{Kn/m}$$

Bending force = **146.62Kn/m**

Max. outside radius calculation

$$\text{Rule 1) Max ER} = \sqrt{(C^2/2)} - (T + Z)$$

Rule 2) IF ER IS > B / 2.2, ER = B / 2.2

Note: Whichever value is the greater is the maximum outside radius possible.

Example:

3mm Material in Model 2.5

$$\text{Rule One) ER} = \sqrt{(25.17^2/2)} - (3 + 2) \\ 17.8 - 5 = 12.8$$

Rule Two) $2 = 26.34 / 2.2 = 11.97$

12.8 (Rule One) is greater than 11.97 (Rule Two)

therefore **Max ER = R12.8mm**

Min. flange calculation

$$\text{Min flange (MF)} = \sqrt{(B^2/2)}$$

Example:

Min flange calculation example:

Model 1

$$\text{Min flange (MF)} = \sqrt{(7.17^2/2)} \\ \sqrt{25.704} = 5.07$$

Min Flange = **5.07mm**

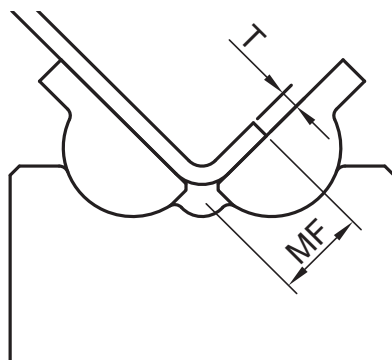

General input on machine

Equivalent V construction for graphical machine controllers

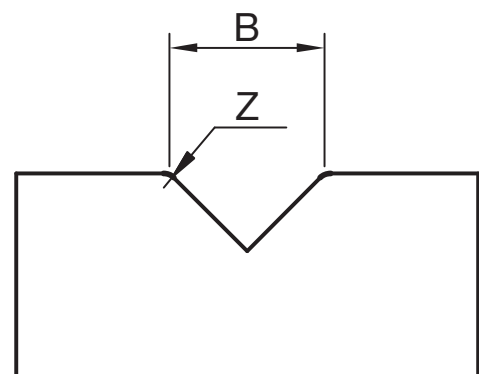

To simulate the Rolla-V on a machine graphical input, use a v-width of **B** and v-corner radius of **Z**.

This catalogue illustrates our standard range of tools.

If you cannot see the product that you require we can make bespoke tools to order based on your own individual specification.

Please call to discuss your individual requirements.



+44 (0)845 500 1900

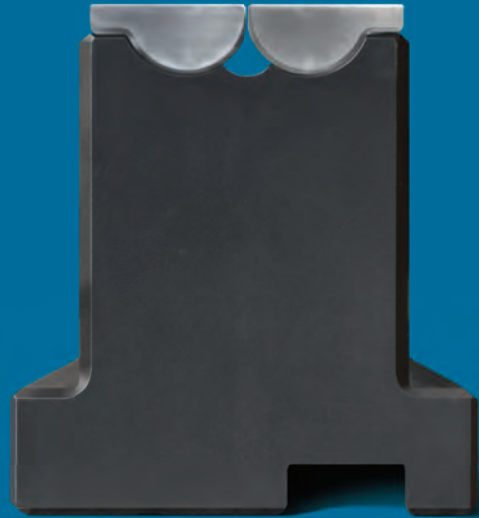

t: +44 (0)1384 414100

e: sales@rolla-v.com

Rolla-V | Press Brake Tooling

7 Park Lane Industrial Estate

Bassett Road

Halesowen

West Midlands

UK

B63 2RE



Tooling Hotline:
+44 (0)845 500 1900



Scan the code to watch
Rolla-V in action



www.rolla-v.com

designed and manufactured
in the UK